

## 3M™ Drive-Thru Basestation G5

### Wiring a D-15 as a Backup Communication System to the 3M™ Drive-Thru Basestation G5 using an External Backup Switch

#### Overview

A backup Intercom system is a wired or wireless communication system that can be used as a backup in the unlikely event of 3M™ DriveThru Basestation G5 failure.

In August of 2016, 3M sold the Wired Communication Products including the D-15 Intercom to RDM Industrial Electronics, Inc. (RDM). Unlike the 3M™ Wireless Communication System Model XT-1, the 3M™ Drive-Thru Basestation G5 does not have a built-in backup switch. RDM has developed an external Backup Switch to integrate the D-15 with 3M™ Drive-Thru Basestation G5. These components can be purchased directly from RDM by contacting them at 800-282-5183 or [www.rdm.net](http://www.rdm.net).

- D-15 Backup Switch (Part# RDM8229)
- D-15 Intercom (Part# RDM8118)

**NOTE:** The D-15 Backup Switch is designed to provide backup communication any ONE lane ONLY. In the event the store has a Dual Lane G5 Basestation in operation, you may choose to install the D-15 Intercom as a backup system on either Lane1 OR Lane2.

#### Pre-Requisites

This Technical Bulletin assumes the following:

- Installed the D-15 Intercom as a backup, per instructions provided in its installation manual, and
- Installed the D-15 Backup Switch per instructions provided and is ready to be wired, and
- Installed the 3M™ Drive-Thru Basestation G5 per instructions provided in the 3M Installation Manual, and
- Installed an External Vehicle Detector for Order Point Vehicle Detection.

#### Simple Block Diagram

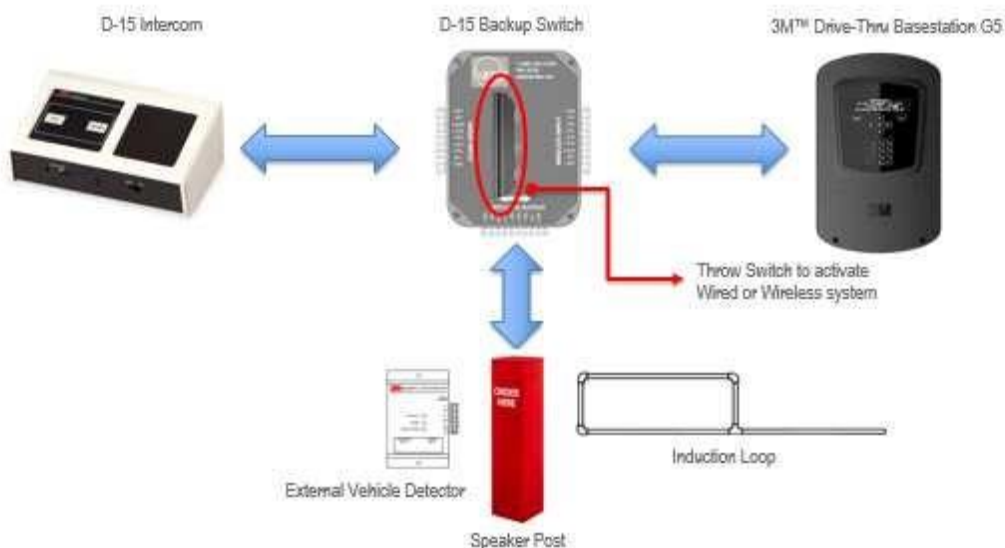



## Connecting the D-15 Intercom System to the Backup Switch

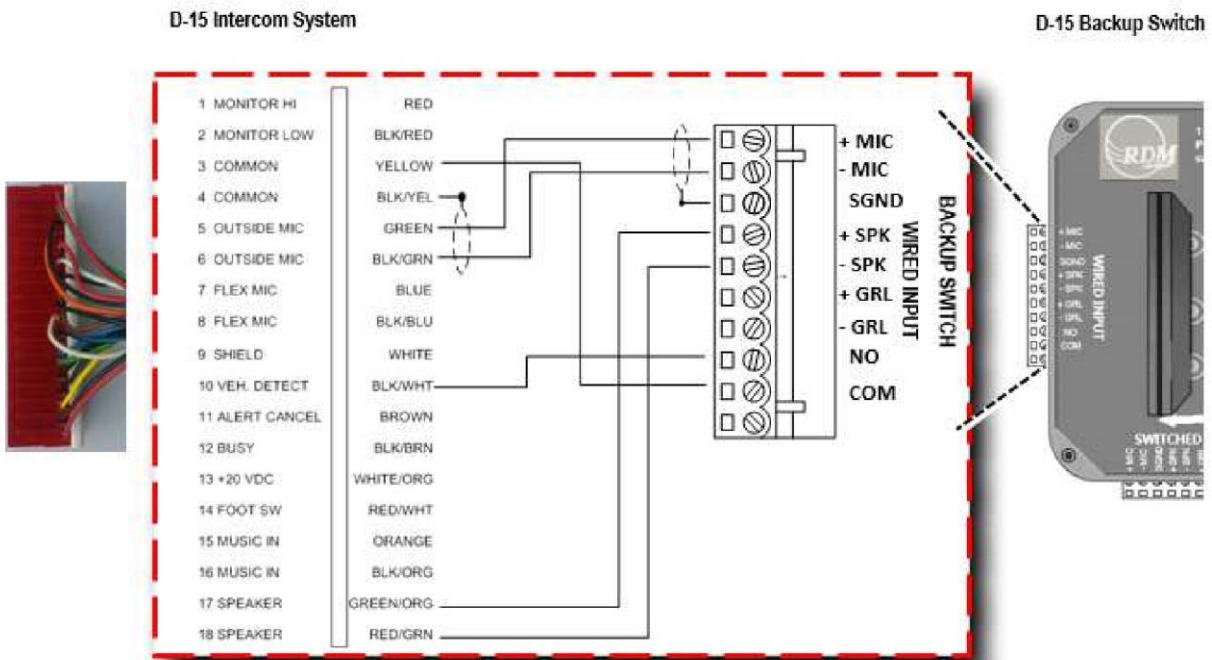

## Connecting the 3M™ Drive-Thru Basestation G5 to the D-15 Backup Switch

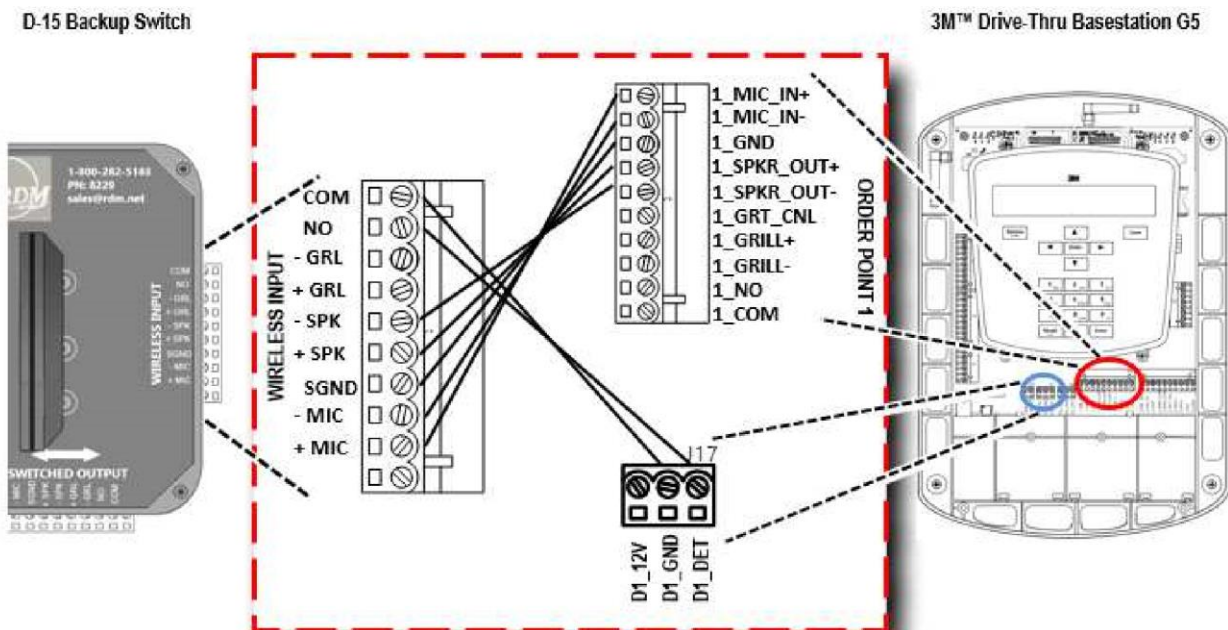

## Connecting Backup Switch to Order Point (Speaker Post) and External Vehicle Detector

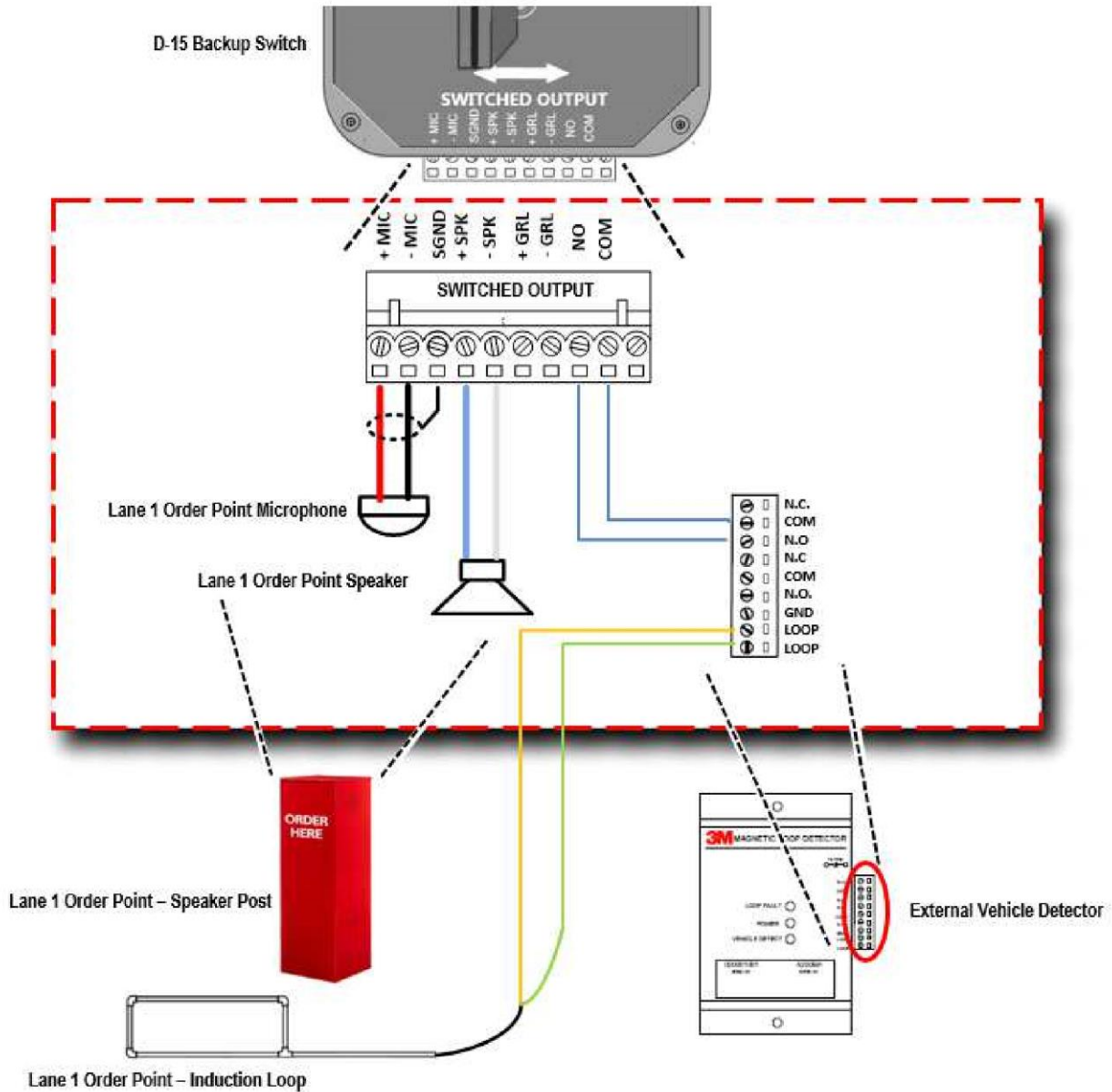

## Technical Information

Technical information and data, recommendations, and other statements provided by 3M are based on information, tests, or experience which 3M believes to be reliable, but the accuracy or completeness of such information is not guaranteed. Such technical information and data are intended for persons with knowledge and technical skills sufficient to assess and apply their own informed judgment to the information. The typical values shown should not be used for the purpose of specification limits. If you have questions about this Product, contact the Technical Service helpline at 1-800-328-0033.

## Product Use

Many factors beyond 3M's control and uniquely within user's knowledge and control can affect the use and performance of a 3M product in a particular application. Given the variety of factors that can affect the use and performance of a 3M product, user is solely responsible for evaluating the 3M product and determining whether it is fit for a particular purpose and suitable for user's method of application.

## 3M Basic Product Warranty

The Product(s) specified in this document are warranted to be free of defects in materials and manufacture ("3M Basic Product Warranty") on the date of shipment ("Warranty Period") by 3M or its authorized distributor.

## Limitation of Liability

3M WILL NOT UNDER ANY CIRCUMSTANCES BE LIABLE TO A BUYER FOR DIRECT (other than the Limited Remedy stated above), SPECIAL, INCIDENTAL, INDIRECT OR CONSEQUENTIAL DAMAGES (INCLUDING, WITHOUT LIMITATION, LOSS OF PROFITS) IN ANY WAY RELATED TO THE PRODUCT, THIS DOCUMENT OR OTHER PRODUCT INFORMATION, REGARDLESS OF THE LEGAL OR EQUITABLE THEORY ON WHICH SUCH DAMAGES ARE SOUGHT.

## No Extension of Warranty

In the case of an approved warranty claim, the replacement Product will carry only the remaining term of the original warranty period.

## Limited Remedy

IF ANY PRODUCT IS PROVEN NOT TO HAVE MET THE 3M BASIC PRODUCT WARRANTY OR THE 3M LIMITED WARRANTY DURING THE WARRANTY PERIOD, THEN THE BUYER'S EXCLUSIVE REMEDY, AND 3M'S SOLE OBLIGATION, WILL BE, AT 3M'S OPTION, TO REPLACE THE NONCONFORMING PRODUCT OR TO REFUND THE NONCONFORMING PRODUCT'S PURCHASE PRICE.

**Commercial Solutions** 3M Center, Building  
220-12E-04 St. Paul, MN 55144

1-800-328-0033

3M.com/Facility

© 3M 2017. All rights reserved.

3M is a trademark of 3M. Used under license in  
Canada.

All other trademarks are property of their  
respective owners.

Please recycle. Revision A, July 2017

